

Effect of addition of the CuO-Fe₂O₃ system on the electromagnetic wave absorbing properties of sintered ferrite

K. Y. KIM, W. S. KIM, Y. D. JU, H. J. JUNG

Division of Ceramics, Korea Institute of Science and Technology, PO Box 131, Cheongryang, Seoul, Korea

The effects of the addition of the CuO-Fe₂O₃ system as a liquid former on the microstructure and electromagnetic wave absorbing property of sintered Ni-Zn ferrite were investigated. The CuO-Fe₂O₃ system, a spinel ferrite, has its own magnetic property, which enables it to be used as an electromagnetic wave absorber. The CuO-Fe₂O₃ system was preferentially located at the grain boundary in the matrix of an Ni-Zn ferrite. This resulted in an increase in the total loss and a decrease in matching thickness. The centre frequency shift is presumed to occur because Ni-Zn ferrite with CuO-Fe₂O₃ behaves like a mixture of two ferrites with loss characteristics at the different frequency ranges.

1. Introduction

As information-oriented modern society develops and diversifies with rapid advancement of communication technology, "wave pollution" problems are drawing extensive public concern. The most common examples of such pollution are the ghost phenomenon on TV sets and malfunction of electronic equipment, caused by interference of unwanted electromagnetic waves of external sources. As a solution, various attempts have been directed towards improving wave transmitting and receiving systems. Another approach that has proved most effective is to absorb unnecessary waves using wave-absorbing materials. Such materials are required to have large electromagnetic loss in the frequency range of interest, and proper modification of electromagnetic properties at the particular frequencies [1, 2].

The most widely used material as an electromagnetic wave absorber is ferrite, which has a low frequency range to be used, due to its resonance characteristics. Various attempts to overcome such limitations have been made [3, 4]. For ferrites, liquid-forming agents used as sintering aids are generally non-magnetic dielectrics, which diminish the loss property of magnets by forming electrically insulating films on the particle surfaces [5]. This detrimental effect can be overcome by the use of sintering aids that possess magnetic loss property and enhance the conductivity at particle surface boundaries.

In this work, the effect of the addition of the CuO-Fe₂O₃ system, a ferrite with a melting temperature of ~1150 °C, as a liquid former, on the microstructure and electromagnetic wave-absorbing properties of sintered Ni-Zn ferrite, was investigated.

2. Specimen fabrication and measurements

The compositions of the CuO-Fe₂O₃ system employed in the present experiment are listed in Table I. These compositions were selected because they have a liquidus temperature of 1150-1200 °C as shown in the CuO-Fe₂O₃ phase diagram (Fig. 1).

The constituent materials were weighed, ball-milled for 24 h and then dried in an oven at 80 °C. The mixture was pressed into coaxial forms (outer diameter of 7 mm, inner diameter of 3 mm) and the CuO-Fe₂O₃ systems were sintered in air at 1150 °C for 1 h.

Complex permittivity, permeability and wave loss were measured by coaxial-type measuring equipment and a network analyser as shown in Fig. 2, to determine the effects of the CuO/Fe₂O₃ ratio on these parameters [6].

The samples were prepared by adding 1, 3 and 5 wt% CuO-Fe₂O₃ system to Ni-Zn ferrite (Ni_{0.6}Zn_{0.4}Fe₂O₄) pre-calcined at 900 °C, followed by sintering the mixture at 1200 °C for 1 h. The measured results for these samples were compared with those for reference specimens made of monolithic Ni-Zn ferrite without addition of CuO-Fe₂O₃.

3. Results and discussion

3.1. Magnetic properties of the CuO-Fe₂O₃ system

Fig. 3 illustrates the relationship between the real part of permeability and frequency for CuO-Fe₂O₃

TABLE I Experimental compositions of the CuO-Fe₂O₃ system (mol %)

	A	B	C	D	E
CuO	40	45	50	55	60
Fe ₂ O ₃	60	55	50	45	40

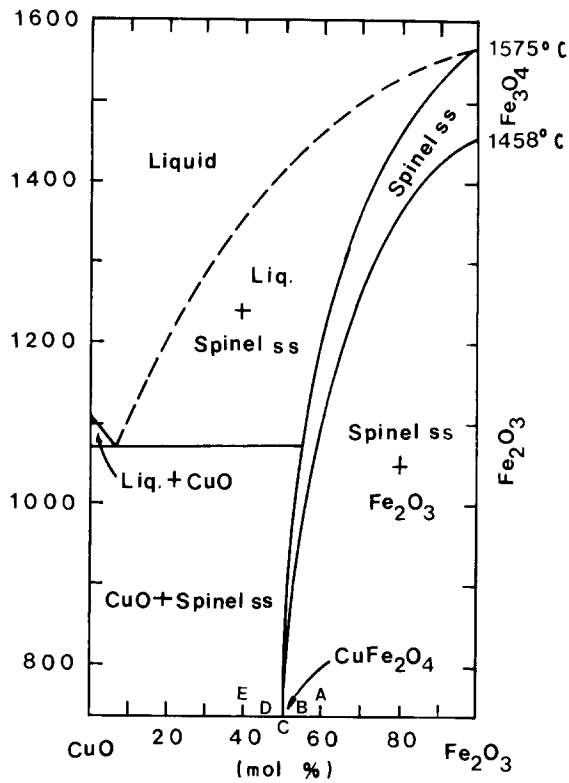

Figure 1 Phase diagram and experimental compositions of the CuO-Fe₂O₃ systems.

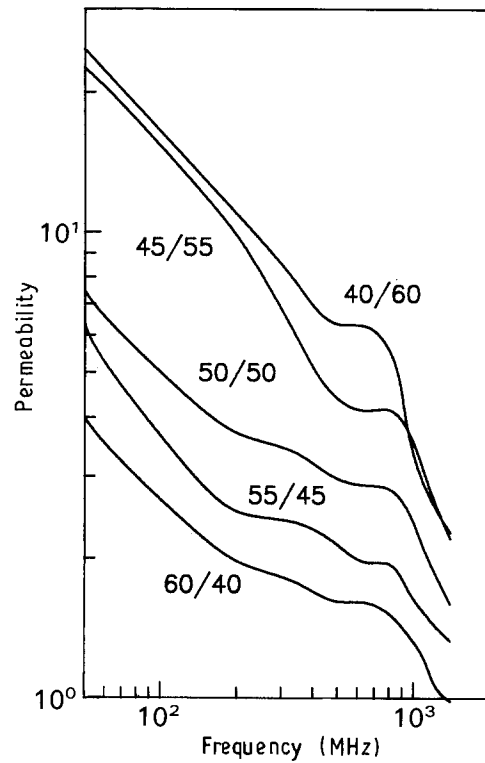

Figure 3 Real part of permeability for CuO-Fe₂O₃ systems (mol %) versus frequency.

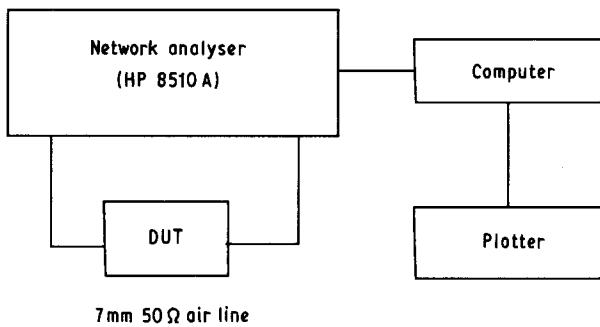

Figure 2 Arrangement of the measuring system.

samples. Permeability generally decreased with increasing amount of CuO. This observation agrees with the fact that the theoretical magnetic moment, μ_B , decreases from 4 for monolithic Fe₃O₄ to 1 for stoichiometric composition CuFe₂O₄, as the amount of CuO increases.

The resonance frequency decreases as the initial permeability increases [7]. Thus the effective frequency range, where over 20 dB loss occurs, shifted to higher frequency as the amount of CuO increased (Fig. 4).

3.2. Effects of CuO-Fe₂O₃ addition on properties of sintered ferrites

CuO-Fe₂O₃ ferrite in this experiment could be expected to melt below the conventional sintering temperature of ferrite, ~ 1200 °C, and to locate preferentially at the grain boundary in the matrix of Ni-Zn ferrite, as shown in Fig. 5.

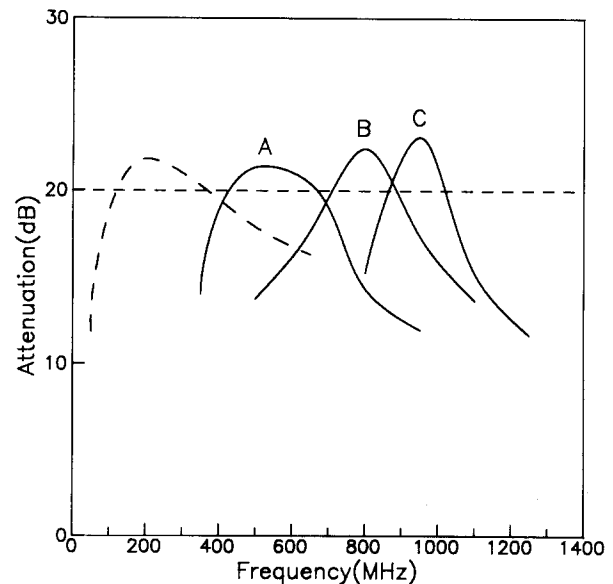

Figure 4 Attenuation behaviour of monolithic Ni-Zn ferrite with compositions A, B and C of CuO-Fe₂O₃ systems.

According to past investigations [5], non-uniform magnetic properties caused by compositional inhomogeneity of the sintered ferrite increase eddy current loss and, consequently, total loss of the ferrite. This resulted in an increase in the total loss, with which thinner matching thickness can be expected [1].

A Smith chart in Fig. 6 illustrates input impedance variation for sintered Ni-Zn ferrite without and with 5 wt % Composition C of the CuO-Fe₂O₃ system. Impedance values represented by the circumference in the Smith chart indicate 100% reflection and that by the centre point, 100% absorption. In reality, 99.0%

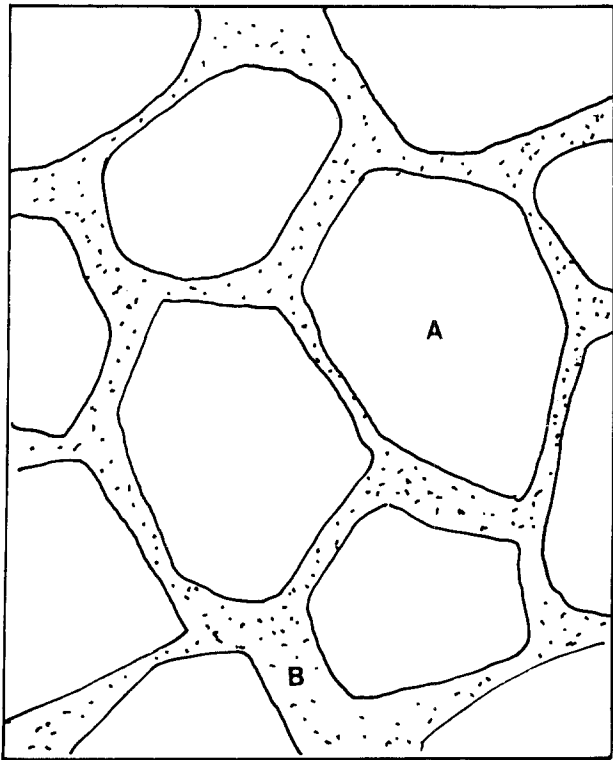

Figure 5 Schematic representation of the microstructure of sintered ferrite with CuO-Fe₂O₃ systems. A, Ni-Zn matrix system; B, CuO-Fe₂O₃ systems.

absorption (1% reflection) is adopted as a practical limit for reflection conditions, because real electromagnetic waves to be absorbed spread broadly in frequency, and matching conditions vary with change in frequency. Matching ranges defined in this manner correspond to less than 1 of $(Z_{in(2)} - 1)/(Z_{in(2)} + 1)$ in the absolute value and the inside area of the small circle on the Smith chart.

Compared to monolithic ferrite, ferrites with Composition B of CuO-Fe₂O₃ were previously shown to exhibit a broader effective frequency range and decreased matching thickness. Magnetic loss in ferrite materials, divided into eddy current loss, residual loss by the resonance phenomenon and hysteresis loss by an external magnetic field, can be formulated as [8]

$$\begin{aligned} \tan \delta_m &= \tan \delta_h + \tan \delta_f + \tan \delta_r \\ &= k_1 B + k_2 f + k_3 \end{aligned} \quad (1)$$

where k_1 , k_2 and k_3 are constants, $\tan \delta_m$, $\tan \delta_h$, $\tan \delta_f$, $\tan \delta_r$, B and f represent total loss, hysteresis loss, eddy current loss, residual loss, flux density and frequency, respectively. When a ferrite is used as the wave absorber (no hysteresis loss), eddy current loss increases linearly with increasing frequency. On the other hand, residual loss maintains a constant value irrespective of frequency up to the resonance frequency, above which it abruptly increases and becomes a dominant loss source. This frequency-dependence of magnetic loss is schematically presented in Fig. 7. It should be noted that the eddy current loss contributes dominantly in the low-frequency range below the resonance frequency. This explains why CuO-Fe₂O₃ addition to ferrite exhibits a wave absorbing property in the low

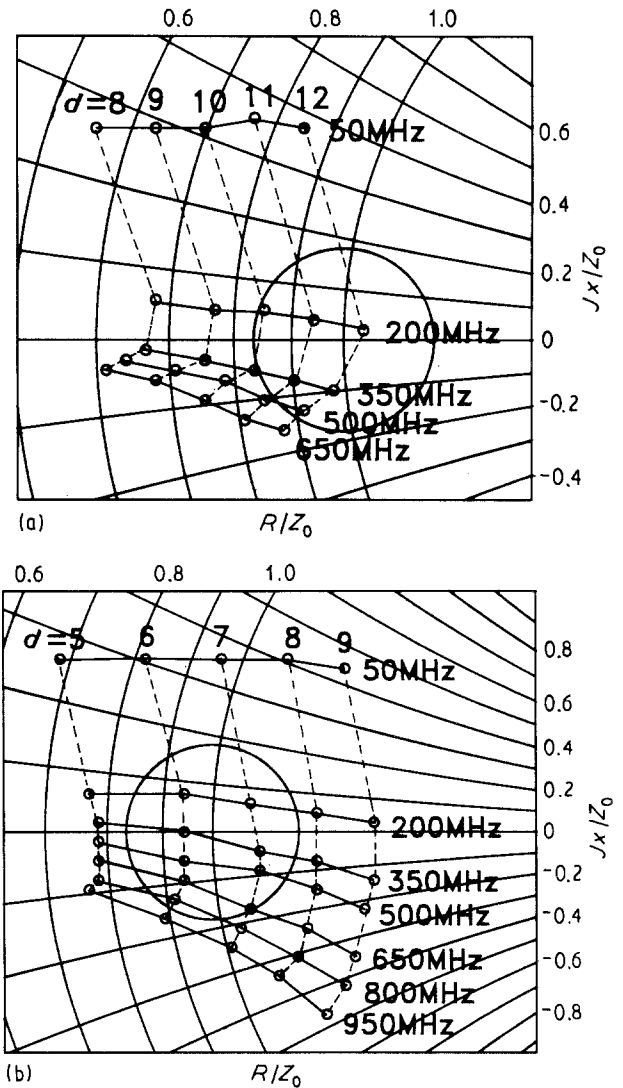

Figure 6 Loci of input impedance for (a) monolithic Ni-Zn ferrite, (b) Ni-Zn ferrite with 5 wt % CuO-Fe₂O₃ (Composition C) d is the thickness (mm).

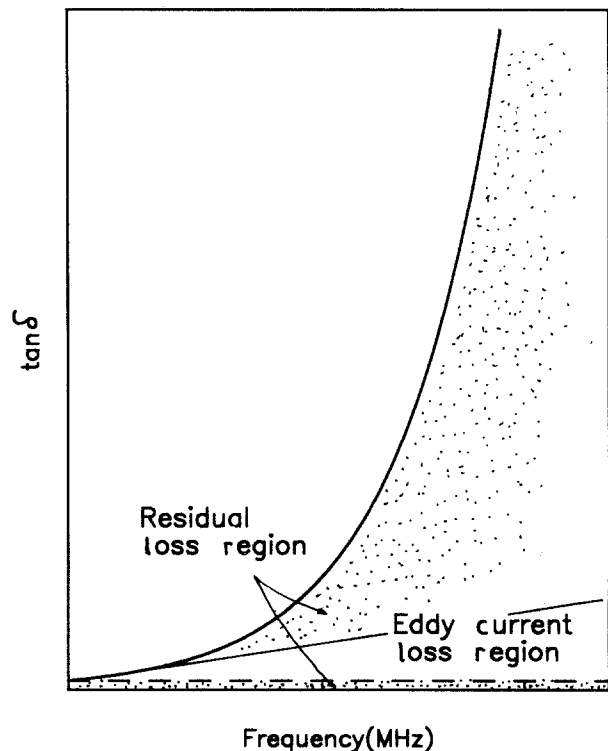

Figure 7 Schematic representation of $\tan \delta$ of the ferrite.

frequency range, where monolithic ferrites were ineffective.

The centre frequency (frequency at the maximum point of the attenuation curve) shift is presumed to occur because Ni-Zn ferrite with CuO-Fe₂O₃ behaves like a mixture of two ferrites with loss characteristics at the different frequency ranges. This effect occurs in all compositions of the CuO-Fe₂O₃ system,

as shown in Table II. The more CuO-Fe₂O₃ is added, the higher the centre frequency moves to. This trend becomes clearer with increasing CuO/Fe₂O₃ ratio.

Scanning electron micrographs of sintered Ni-Zn ferrites with 1, 3 and 5 wt % Composition C CuO-Fe₂O₃ are compared with that of monolithic Ni-Zn ferrite in Fig. 8. CuO-Fe₂O₃ addition effectively enhanced the development of homogeneous

TABLE II Properties of sintered samples with the CuO-Fe₂O₃ system

CuO	Fe ₂ O ₃	Amount of addition (wt %)	μ'' (50 MHz)	Thickness (mm) ^a	Frequency range (MHz) ^b
40	60	1	123	7.0	113-725
		3	115	7.3	130-800
		5	127	6.5	141-800
45	55	1	122	7.2	98-683
		3	128	6.7	98-800
		5	124	6.8	137-875
50	50	1	118	7.4	106-725
		3	120	7.2	122-875
		5	129	6.4	148-875
55	45	1	119	7.3	110-762
		3	126	6.7	143-800
		5	117	7.0	151-950
60	40	1	123	7.0	118-800
		3	125	6.8	125-821
		5	132	6.1	149-830
Monolithic Ni-Zn ferrite			65	11.7	139-530

^a Matching thickness.

^b Effective frequency range.

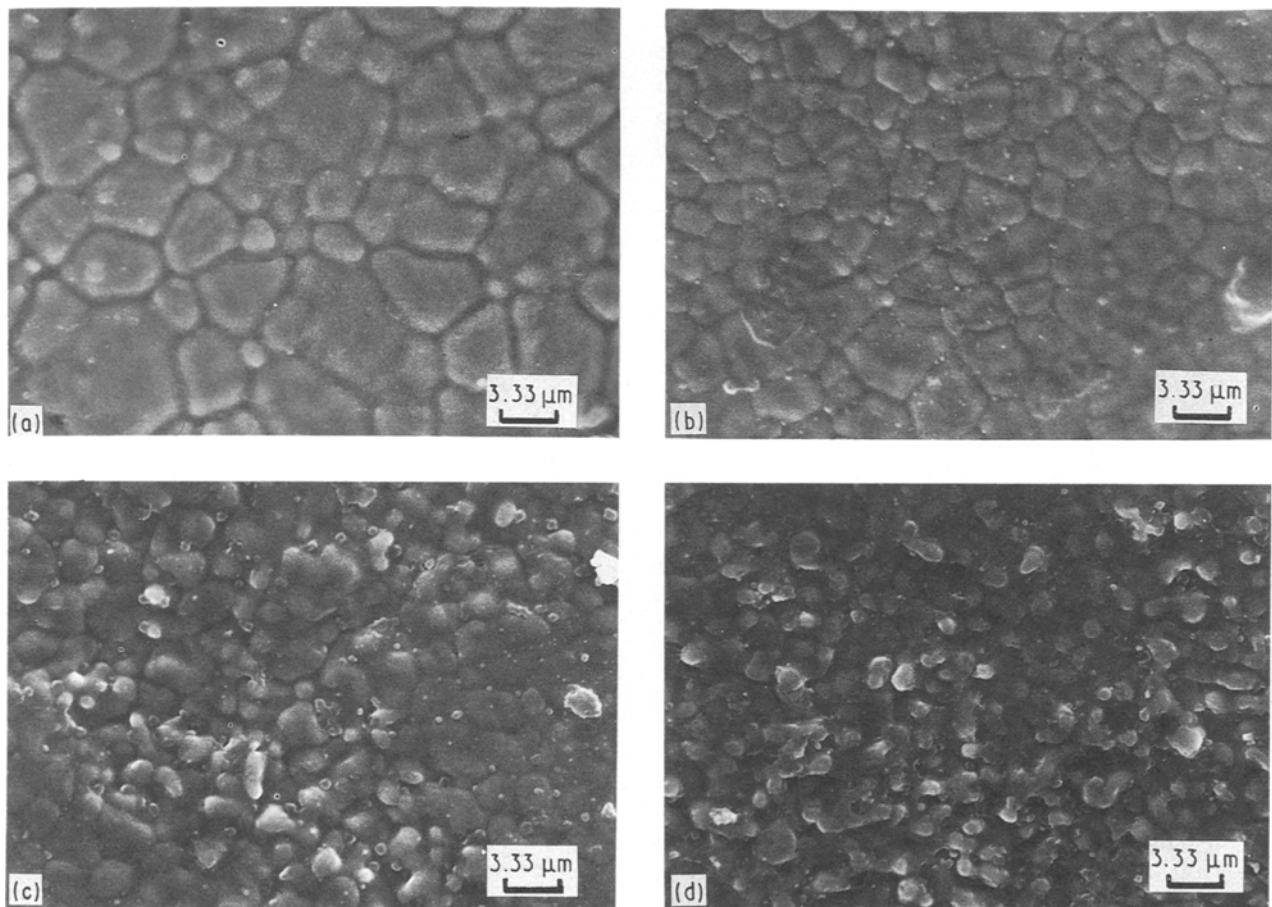

Figure 8 Scanning electron micrographs of sintered ferrite bodies. (a) Monolithic Ni-Zn ferrite. (b) 1 wt % addition of Composition C. (c) 3 wt % addition of Composition C. (d) 5 wt % addition of Composition C.

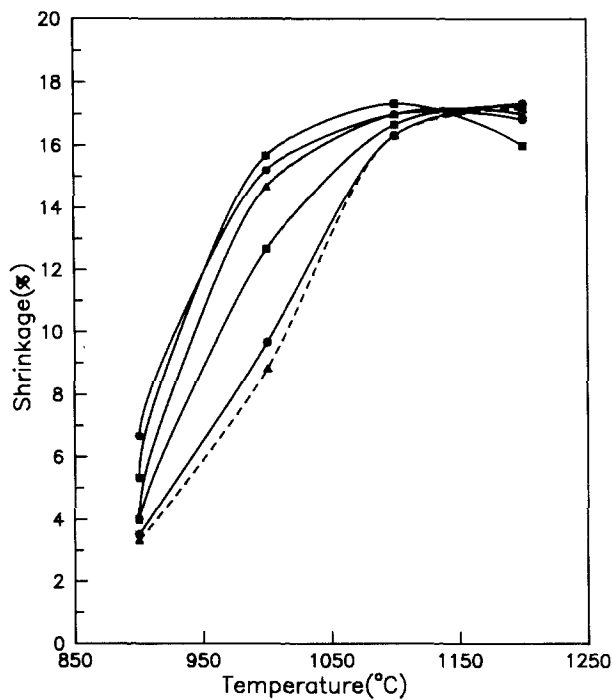

Figure 9 Shrinkage curves of sintered Ni-Zn ferrite with and without addition of 5 wt % of (○) A, (□) B, (△) C, (■) D and (●) E, and (▲) monolithic Ni-Zn.

microstructure with finer grain size. Fig. 9 shows the shrinkage curves of sintered Ni-Zn ferrite with and without 5 wt % CuO-Fe₂O₃ systems. Fig. 10 shows the attenuation behaviour of Ni-Zn ferrite with and without CuO-Fe₂O₃ systems: addition of CuO-Fe₂O₃ to Ni-Zn ferrite reduces the thickness and widens the effective frequency range of wave absorbers.

4. Conclusion

In this study, effects of CuO-Fe₂O₃ with ferritic crystal structure and magnetic property added to the ferrite matrix as liquid former, were investigated. The following conclusions were derived.

1. CuO-Fe₂O₃ system added to ferrite was found to be an effective liquid-forming sintering aid. With its addition, homogeneous and fine grain-size sintered ferrite could be obtained.

2. The CuO-Fe₂O₃ system exhibited common magnetic properties of spinel ferrites and possessed its own wave-absorbing property.

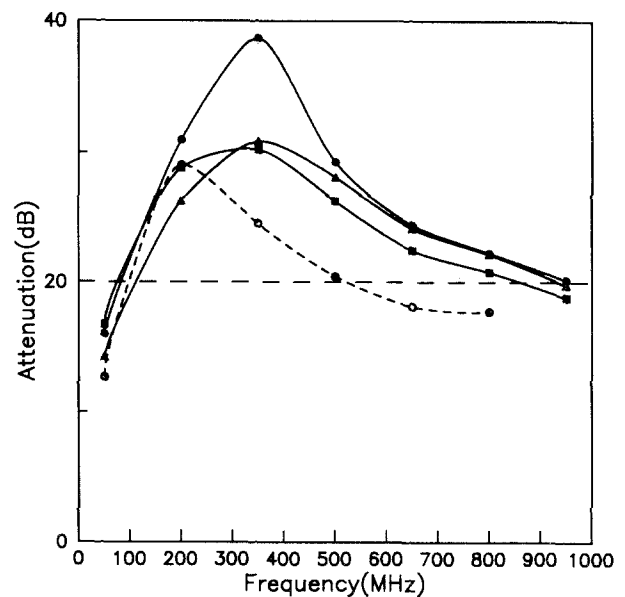

Figure 10 Attenuation behaviour against frequency of wave absorber with and without additives. Absorber thickness: (○) Monolithic ferrite, 11 mm; (■) 1 wt % Composition C 7 mm; (●) 3 wt % Composition C 7 mm; (▲) 5 wt % Composition C 6 mm.

3. The addition of CuO-Fe₂O₃ to ferrite matrix moved the centre frequency of the wave absorber to high frequency, induced a decrease in matching thickness and increased the effective frequency range. These effects increased with increasing amount of CuO-Fe₂O₃ or the CuO/Fe₂O₃ ratio.

References

1. K. ISHINO, *Jpn. Electron. Ceram.* **19**(95) (1988) 20.
2. T. INUI "Electromagnetic Wave Absorber-Application of Ferrite By-product," NEC Technical Report, **37**(9) (1984) pp 2-13.
3. K. SUETAKE *et al.*, US Pat. 3754255, (1973).
4. FUJIDA IND., Jap. Pat. 2-16038, (1990).
5. K. ISHINO *et al.*, *Amer. Ceram. Bull.* **66** (1987) 1469.
6. A. M. NICOLSON *et al.*, *IEEE Trans. Instrum. Meas.* **IM-19** (1970) 377.
7. Y. NAITO and K. SUETAKE, *IEEE Trans. Micro. Theory Tech.* **MTT-19**(1) (1971) 65.
8. E. C. SNELLING, "Soft Ferrite-Properties and Application", 2nd Edn (Butterworth, 1988) pp. 33-9.

Received 1 May
and accepted 12 September 1991